

Data Sheet

260W-08058-ABC

water-cooled motor / generator with 47 kW power

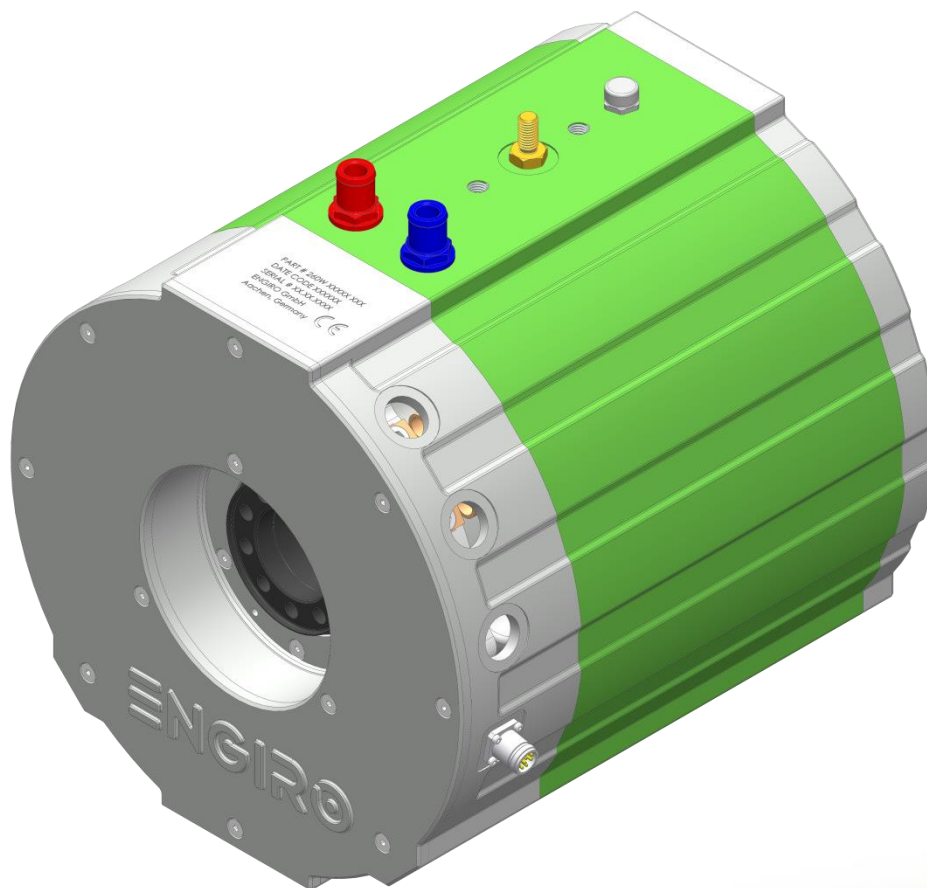

KEY FEATURES

- permanent magnet synchronous machine
- water-cooled
- high peak power for motor applications
- convincing cost-benefit ratio
- recommended voltage range from 500V to 850V
- delivery with controller possible

Section	Page
Technical Data Machine	3
Table Shaft and Flange Combinations	4
Technical Drawings Machine	4
Characteristics Machine	5

Data, including specifications, contained within this document are summary in nature and subject to change at any time without notice and are intended for general information only. Call for latest revision. All brand names and product names referenced are trademarks, registered trademarks, or trade names of their respective holders.

Nominal Operation (S2, 30min, cooling as specified below)			
Torque	T_{nom}	222	Nm
Power	P_{nom}	47	kW
Speed	n_{nom}	1940	rpm
Phase rms-current	I_{nom}	71 ^{1,2)}	A
Battery voltage (DC)	U_{nom}	700	V
Electric frequency	$f_{el,nom}$	161	Hz
Power factor	$\cos(\varphi)$	0.75	

Maximal Values (S2, 10s, cooling as specified below)			
Torque	T_{max}	443	Nm
Power	P_{max}	80	kW
Phase rms-current	I_{max}	170 ²⁾	A
Battery voltage (DC)	U_{max}	850	V
Speed	n_{max}	3600	rpm
Electric frequency	$f_{el,max}$	300	Hz

Electrical Data			
Number of phases		3	
Number of pole pairs		5	
Maximal efficiency		96	%
T/I constant ($I < I_{nom}$)		3.22	Nm/A _{rms}
U/n constant (AC) at a temperature of 30°C	rms:	194.8	peak: 275.5 V/(1000rpm)
K_e constant (AC) at a temperature of 30°C	rms:	0.372	peak: 0.526 V/(rad*s ⁻¹)

Additional Data			
Weight (w/o cables)		68	kg
Rotor moment of inertia		0.066	kg*m ²
Protection category		IP6K9K ³⁾	
Maximal motor temperature		140	°C
Allowed ambient temperature		-20 ... 45 ⁴⁾	°C
Cooling (medium, flow rate, inlet temperature, pressure)		water/glycol 50/50, 14 l/min, ≤ 45°C, ≤ 0.5 bar	
Temperature monitoring		1 x KTY84-130	
Type approval		CE, EN 60034	
Customs tariff number		8501 5230	

Connectors			
Power terminals		3 x M25 cable gland	
Signal connectors		M16, 10 Pin	
Cooling connectors		2 x ¾" / 19 mm	

¹⁾ Nominal current strongly dependent on cooling as specified below.

²⁾ The cables must not exceed a temperature of 140 °C at any time. Temperature and service life depend on the installation condition.

³⁾ Please note that the IP6K9K rating is only valid if the machine is installed with suitable cable glands and an appropriate sealed interface at the drive side of the motor (flange and/or shaft). Please contact ENGIRO for further questions. / Only applies to SFR Variant / ⁴⁾ other range on request

Data, including specifications, contained within this document are summary in nature and subject to change at any time without notice and are intended for general information only. Call for latest revision. All brand names and product names referenced are trademarks, registered trademarks, or trade names of their respective holders.

Shaft and Flange Combinations For 260W-08058-ABC		Flange (A)
		S (Standard)
Shaft (B)	F (Hollow shaft with two screw flanges)	
Position Sensor (C)		R: Resolver N: None

Other individual combinations are also possible on request.

Technical Drawings

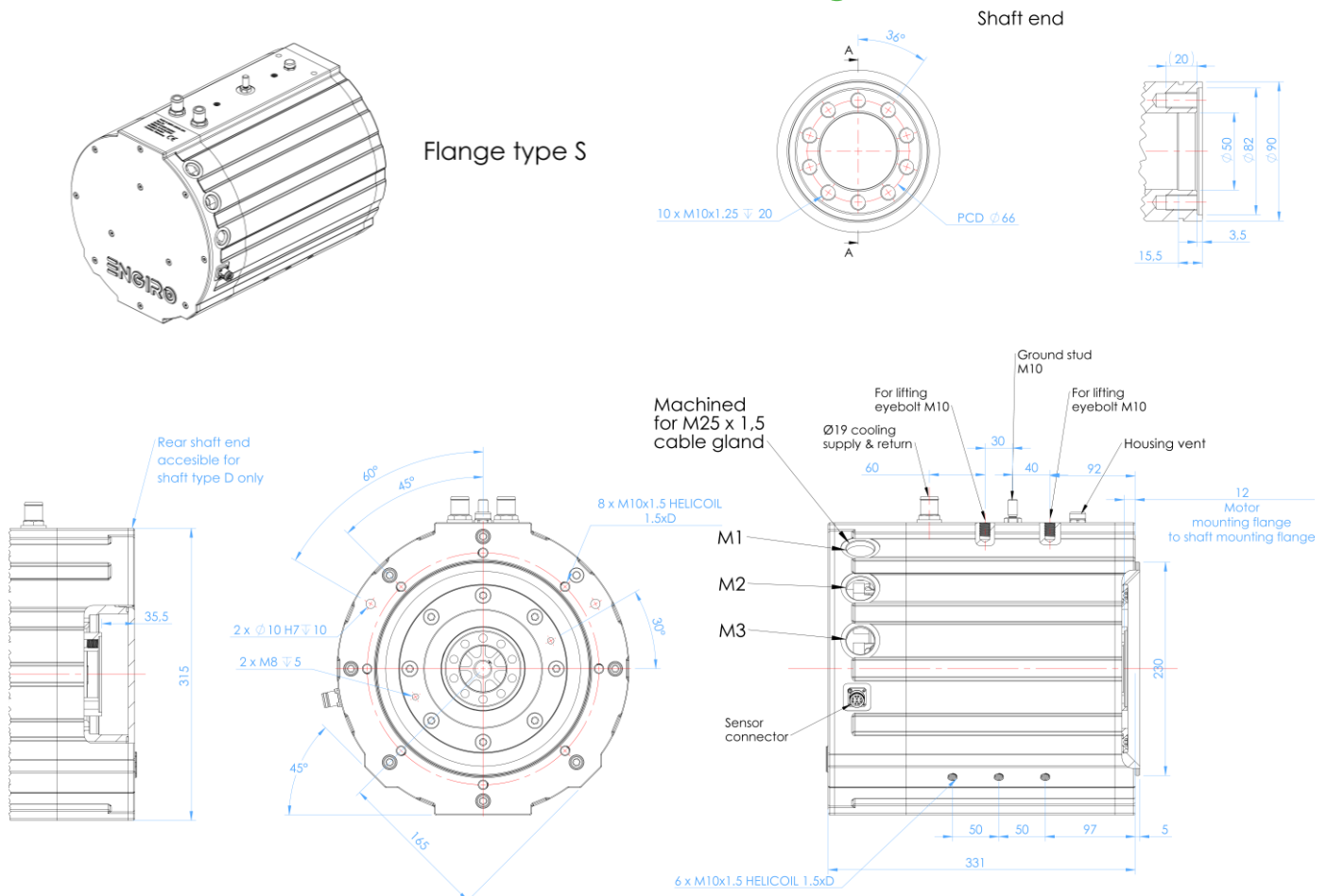

Data, including specifications, contained within this document are summary in nature and subject to change at any time without notice and are intended for general information only. Call for latest revision. All brand names and product names referenced are trademarks, registered trademarks, or trade names of their respective holders.

Simulated Efficiency of Motor Application
(electric machine only; $U_{nom} = 700\text{ V}$; machine at 140 °C ;)

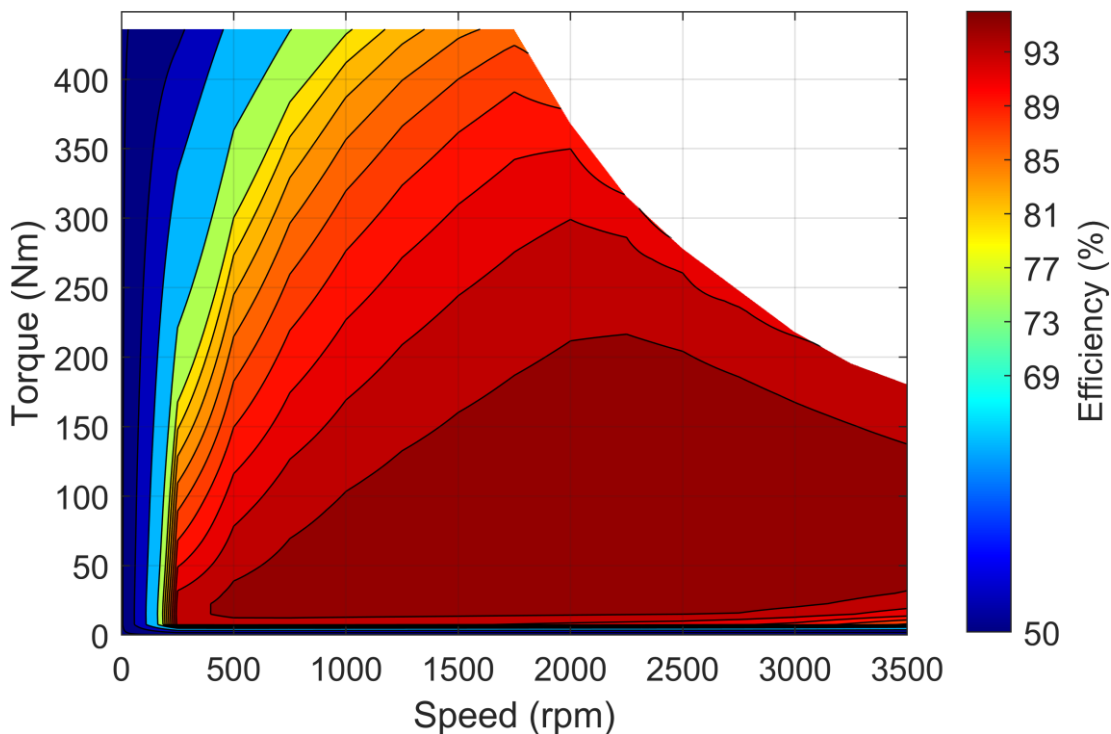

Simulated Characteristic Motor Parameters

$U_{nom} = 700\text{ V}$

solid lines: S2 30min; dashed lines: maximum;

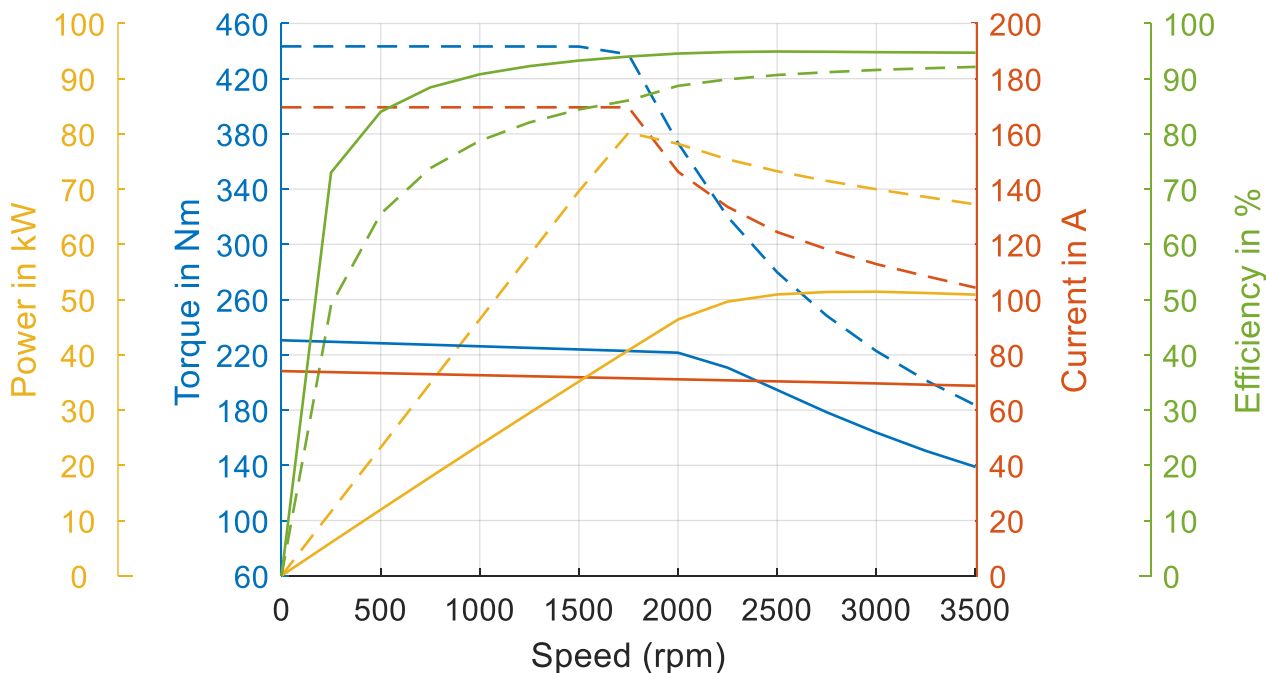

Data, including specifications, contained within this document are summary in nature and subject to change at any time without notice and are intended for general information only. Call for latest revision. All brand names and product names referenced are trademarks, registered trademarks, or trade names of their respective holders.